

SE HYDRAULIKKSYSTEMER 5994

FILE NAMN 835ESA01

DATE	93.10.05
EXEC BY	B.G.S.
TRACED	B.M.E.
REV.	REASON FOR REV. DATE SIGN. APPR. BY

OVERAASEN
MOTORFABRIK & MEKVERKSTED A.S.



SNØFRESER TV-110-150-825 S
Enlinjeskjema

Ø.M.V. 5592
2835

SH	1
OF	

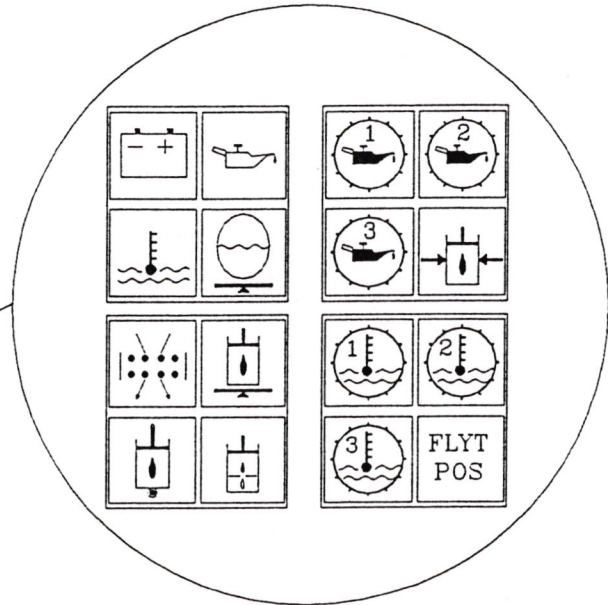
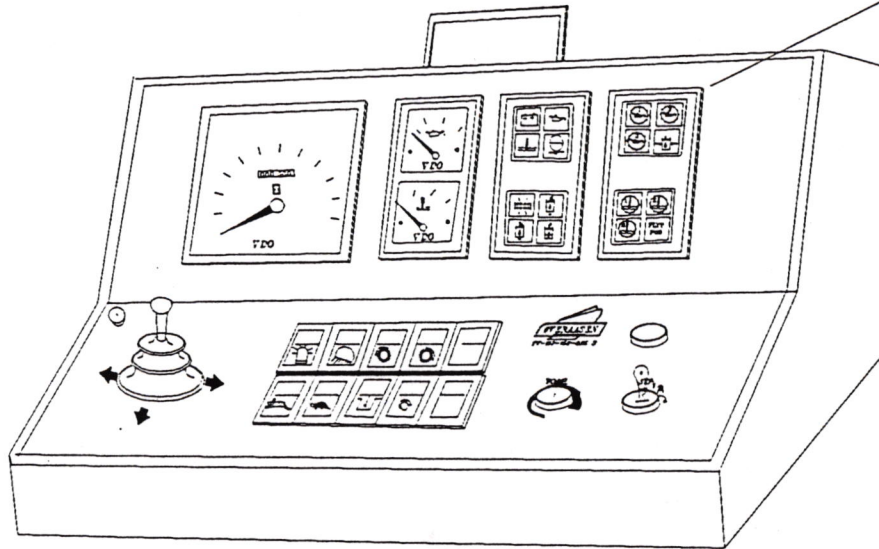

FILE NAM 835GAA01

				DATE	93.10.05
				EXEC. BY	B.G.G.
				TRACED	B.M.E.
REV.	REASON FOR REV.	DATE	SGN.	APPR. BY	

OVERAASEN
MOTORFABRIK & MEKVERKSTED A.S.



SNØFRESEER TV-110-150-825 S
LAYOUT FOR STYREPANEL

ØMV. 5595
2835

-	
+	
SH.	1
OF	

Lavt oljetrykk			Høy temperatur gear			Høy temp. kjølevann	Lavt oljetrykk motor	Lavt nivå kjølevann	Lavt nivå hydr.tank	Høy temp. hydr.olje	Tett luft-filter	Tett hydr. filter	Lavt matetr. drift trommel	Turtall utkast-vifte >800o/min.	Lavt olje-trykk clutch Gear 1
Gear 1 Smareolje	Gear 2	Gear 3A, 3B	Gear 1	Gear 2	Gear 3A, 3B										

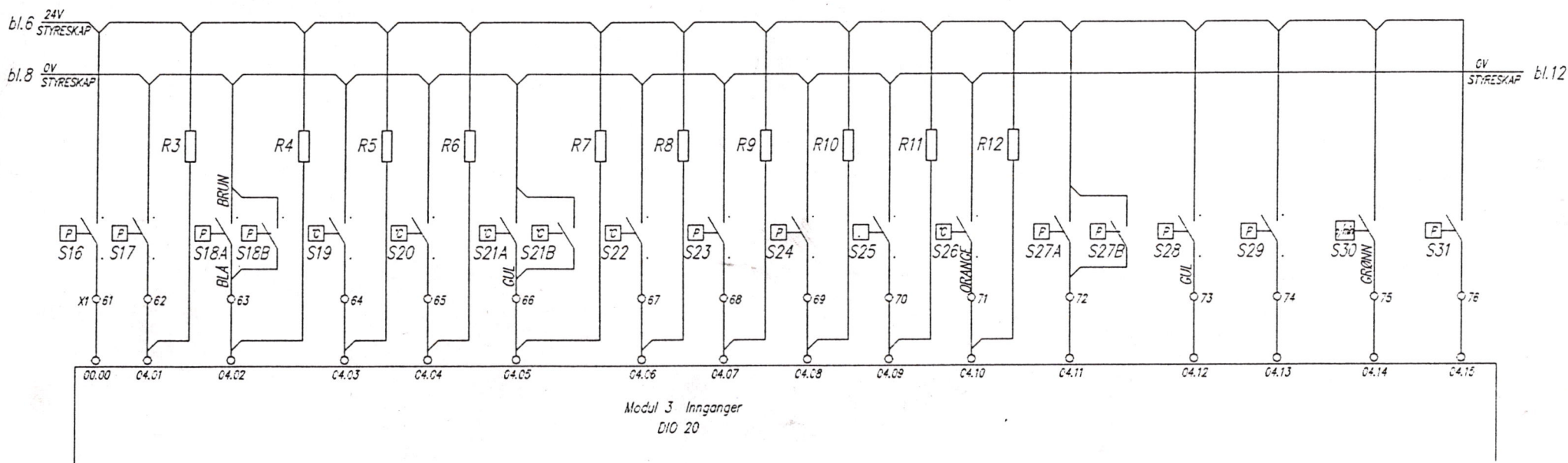

FILE NAM 835ESA11

		DATO 20.10.93		ØVERAASEN A.S.  A.S. INDUSTRIALAUTOMATIK P. box 7044, N-3007 Drammen Tel. 03 27 41 20 Fax 03 27 41 21		Snårfreser TV 110-150-825 S			
		KONSTR. N.A.				2835			
		TRACET B.M.E.				BL 11			
UTGAVE	ENDRING	DATO	SIGN.	GODKJ.	OFFR. TEGN.	ERST. FOR			AV

Lavt oljetrykk			Høy temperatur gear			Høy temp. kjølevann	Lavt oljetrykk motor	Lavt nivå kjølevann	Lavt nivå hydr.tank	Høy temp. hydr.olje	Tett luft-filter	Tett hydr. filter	Lavt matetr. drift trommel	Turtall utkast-vifte >8000/min.	Lavt olje-trykk clutch Gear 1
Gear 1 Smøreolje	Gear 2	Gear 3A, 3B	Gear 1	Gear 2	Gear 3A, 3B										

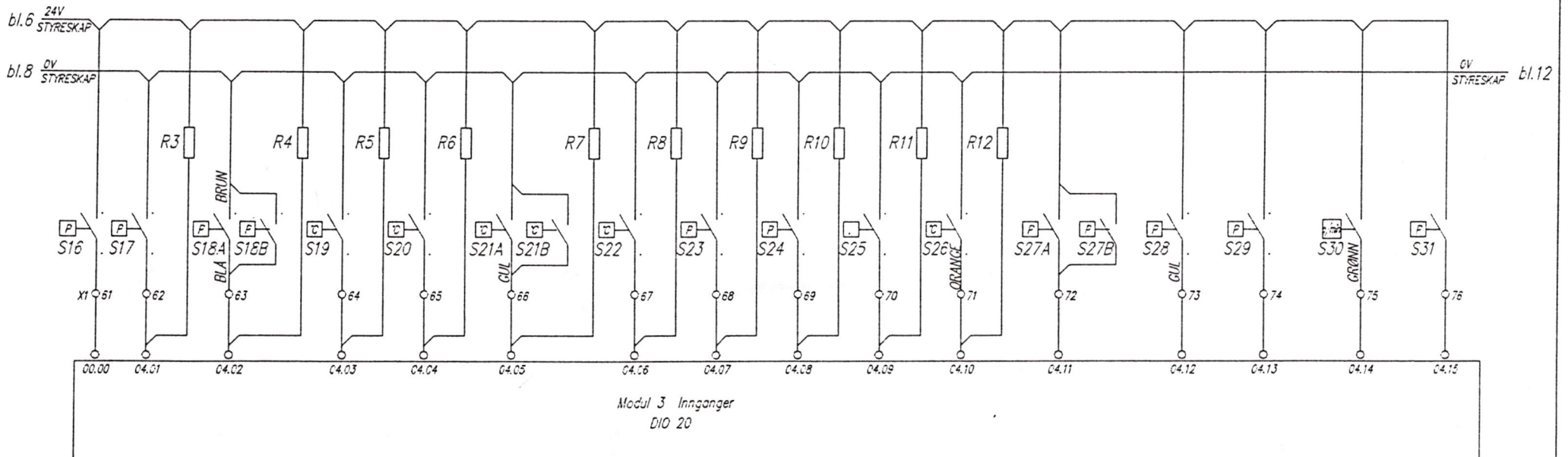

FILE NAVN 835ESA11

UTGAVE	ENDRING	DATO	SIGN.	GDOKL.	OFFR. TEGN.	ERST. FOR

DATA	20.10.93
KONSTR.	N.A.
TRACET	B.M.E.
ØVERAASEN A.S.	



Snøfreser TV 110-150-825 S

2835	BL 11 41'
------	--------------

1 2 3 4 5 6 7 8 9 10 11 12 13 14 15 16

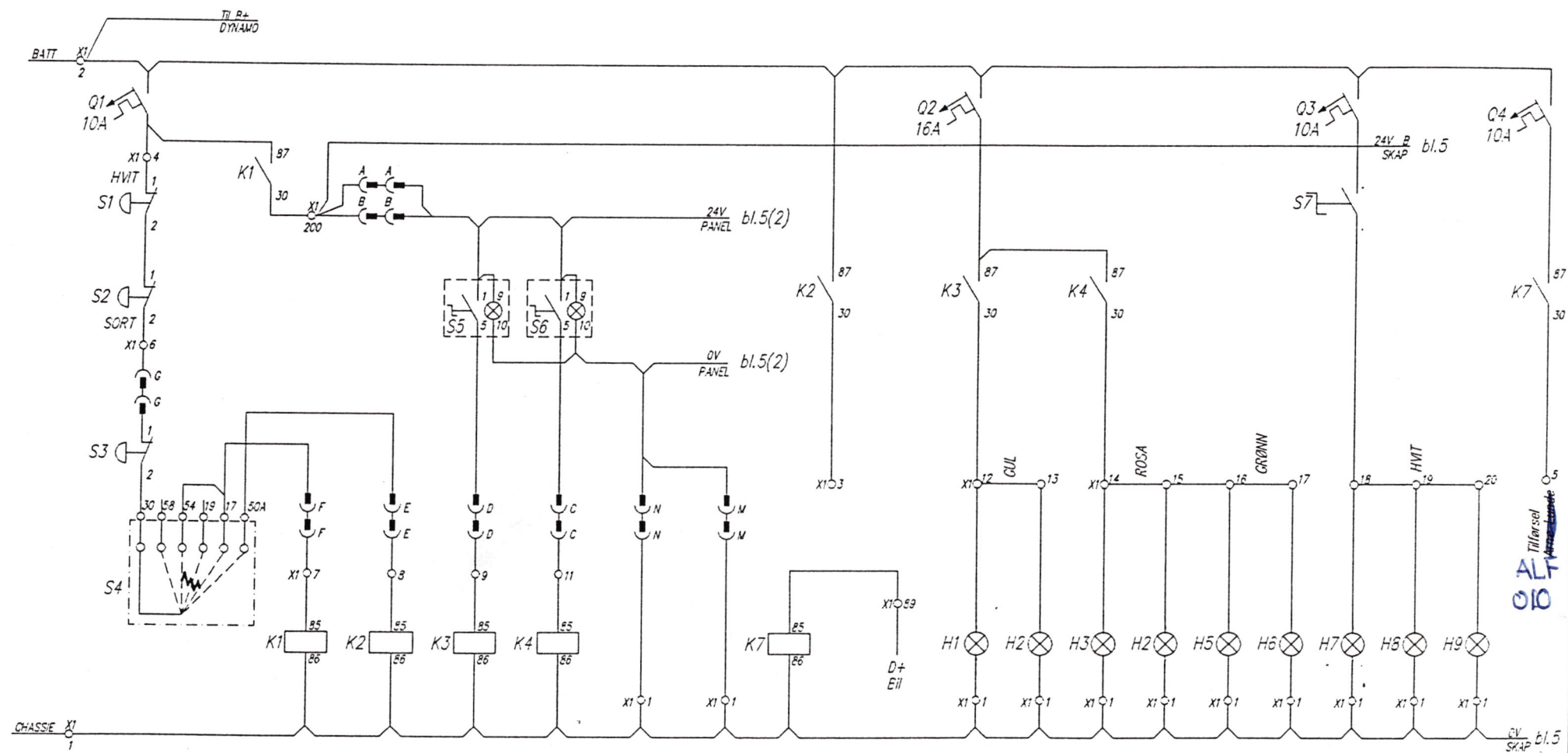

Nedstopp tenning/start	Styrestram rele	Starter rele	Varsellys rele	Arbeidslys rele	B+ Innslag startmotor	Varsel lys	Arbeids- lys	Lys motorrom
---------------------------	--------------------	-----------------	-------------------	--------------------	--------------------------	---------------	-----------------	-----------------

FILE NAMN 835ESA04

UTGÅVE	ENDRING	DATO	SIGN.	GODKJL.
		20.10.93		
		KONSTR.	N.A.	
		TRACET	B.M.E.	

ØVERAASEN A.S.



Snafreser TV 110-150-825 S

2835

-	
+	
BL	4
AV	

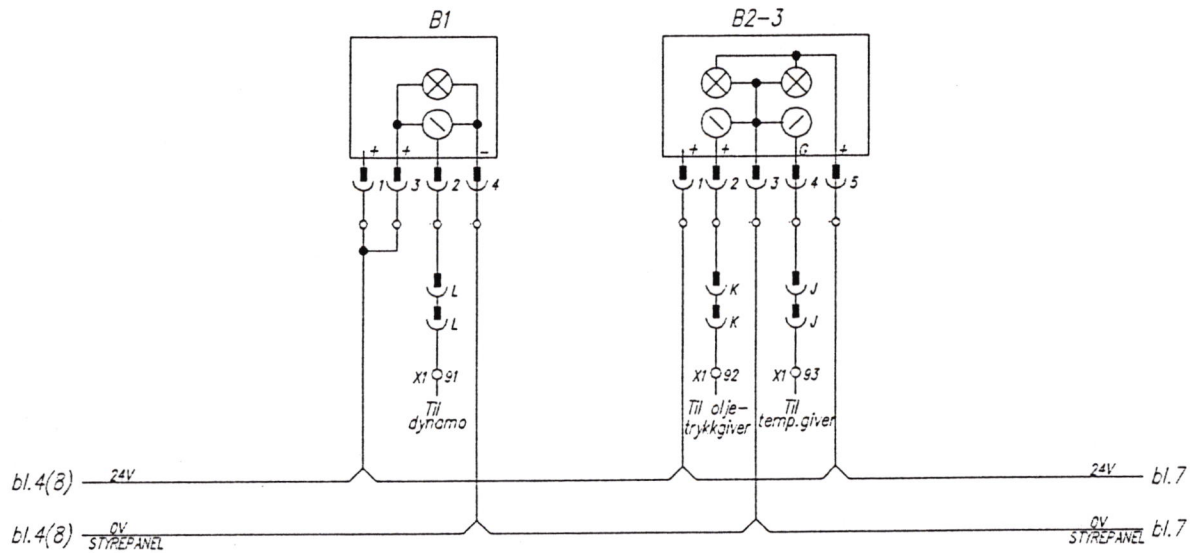

Turteller motor 0-3000 o/min.	Oljetrykk motor 0-10 bar	Temp. kjølevann motor 40-120°C
----------------------------------	-----------------------------	-----------------------------------

FILE NAV 835ESA05

UTGÅVE	ENDRING	DATO	SIGN.	GØKKJ.	GPPR. TEKN.	ERST. FOR	<p>A.S. INDUSTRIAUTOMATIKK P.Box 7044, N-2007 DRAPEREN TELEFON 52 41 00 FAX 52 06 25</p>	Snafreser TV 110-150-825 S Instrumenter	2835	=
										BL 5

ØVERAASEN A.S.

DATO 20.10.93

KONSTR. N.A.

TRACET B.M.E.

Stikke					Turtall		Trommel forover
Venstre	Høyre	Ned	Opp	Flyt	Øke	Minke	

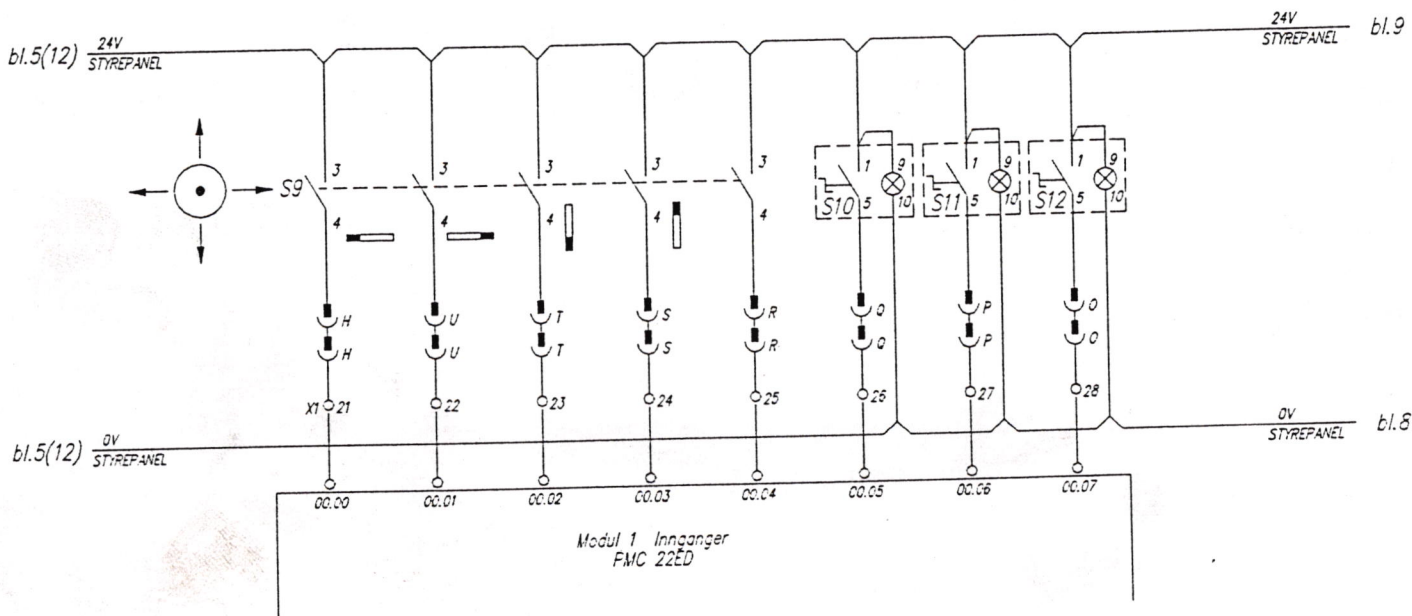

FILE NAM 835ESA07

UTGÅVE	ENDRING	DATO	SGN.	GGOKJ.	BGG	OFFR. TEGN.	ERST. FOR	 ASI A.S. INDUSTRIAUTOMATIK P. box 7044, N-3007 Drammen Tel. 03 87 31 00 Fax 03 87 06 25	Snøfreser TV 110-150-825 S 2835	=	
										BL	7

Modul 1 Utganger
PMC 22ED

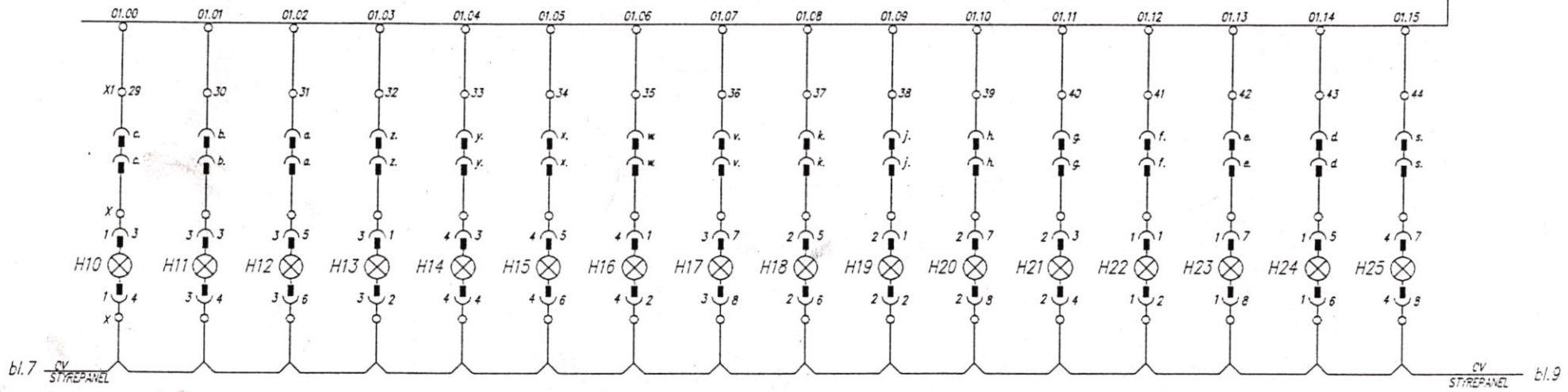

Lamper på styrepanel															
Lading	Lavt oljetrykk			Høy temperatur			Lavt matetr. trommel	Lavt nivå hydr. tank	Høy temp. hydr. olje	Tett hydr. filter	Tett luftfilter	Høy temp. kjølevann	Lavt nivå kjølevann	Lavt oljetrykk motor	Flyt arbeidspos.
	Gear 1 P1 (smøretrykk) P2 (lufttrykk)	Gear 2	Gear 3A, 3B	Gear 1	Gear 2	Gear 3A, 3B									

FILE NAV 835ESA08

Trommel bakover	Kastelengde			Reserve	Max turtall tromml
	Kort Trinn 1	Lang Trinn 2	Enable		

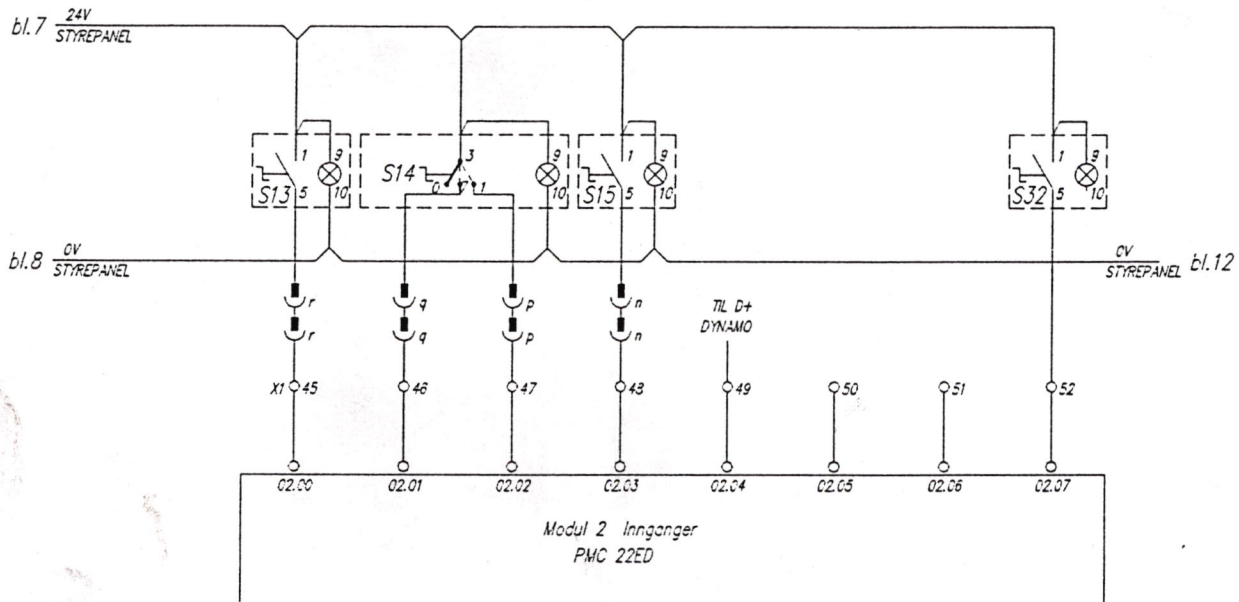

FILE NAV 835ESA09

DATO	20.10.93
KONSTR.	N.A.
TRACET	B.M.E.

ØVERAASEN A.S.



Snafreser TV 110-150-825 S

2835

=	.
+	.
BL	9
AV	.

UTGAVE ENDRING DATO SIGN. GODKJL.

OPPR. TEGN.

ERST. FOR

Modul 2 Utganger
FMC 22ED

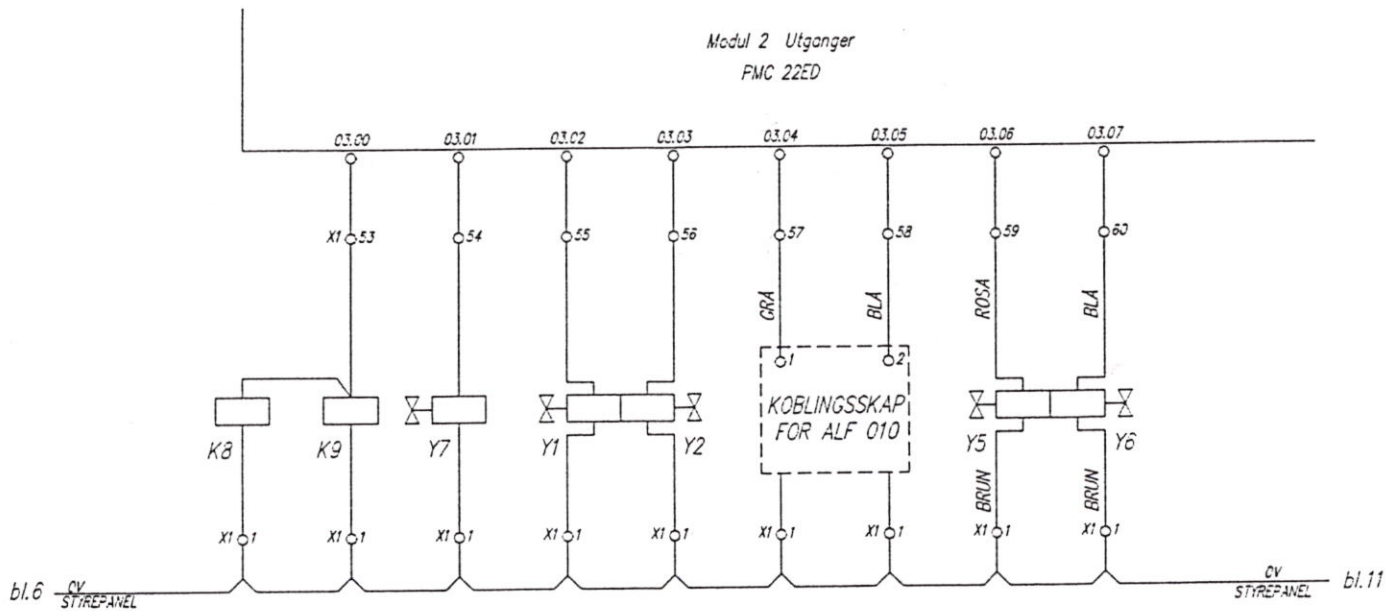

Trommel bakover	Max turtall trommel	Kastelengde		Fres		Utkast	
		Lang	Kort	Left	Senk	Høyre	Venstre

FILE NAVN 835ES410

				DATO	20.10.93
				KONSTR.	N.A.
				TRACET	B.M.E.
UTGAVE	ENDRING	DATO	SIGN.	RODKJ.	

ØVERAASEN A.S.



Snøfreser TV 110-150-825 S

2835

BL	10
AV	

Trommel bakover	Kastelengde			Reserve	Max turtall trommel
	Kort Trinn 1	Lang Trinn 2	Enable		

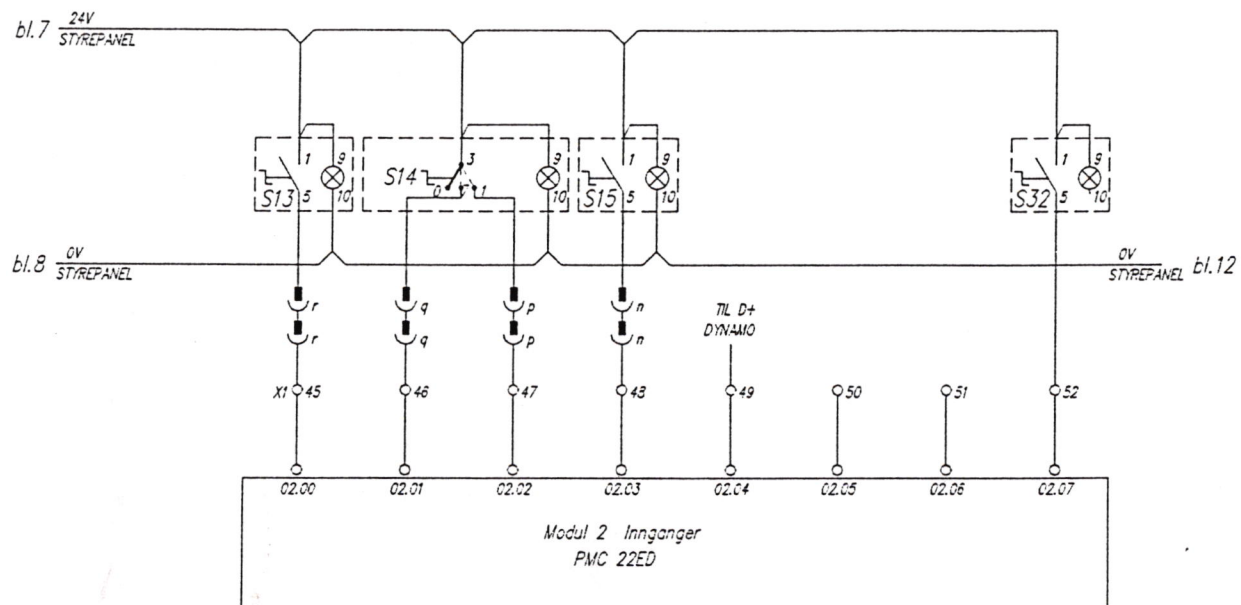

FILE NAM 835ESAD9

UTGAVE	ENDRING	DATO	SIGN.	GDOKJL	OPPR. TEGN.	ERST. FOR
		20.10.93				
		KONSTR.		N.A.		
		TRACET		B.M.E.		

ØVERAASEN A.S.



Snafreser TV 110-150-825 S

2835

=
+
BL 9
AV

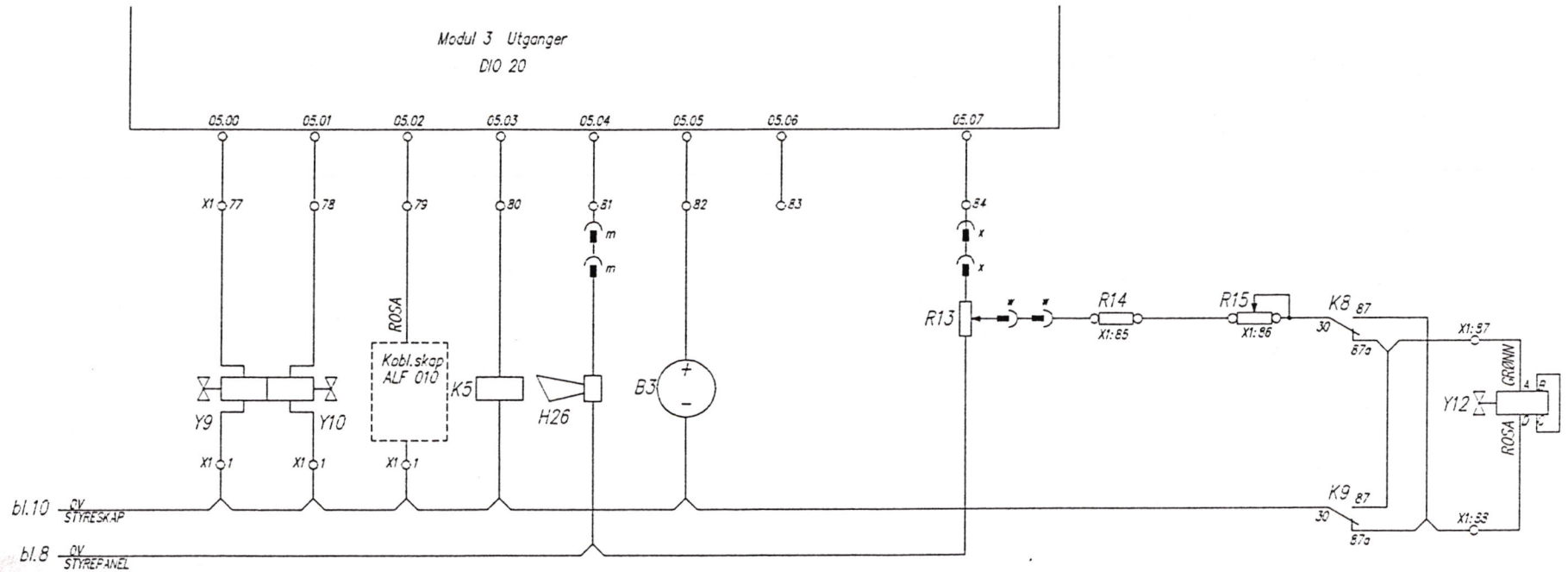

Motorturtall		Fres flytstilling	Rele for stoppmagnet	Lydgiver styrepanel	Timeteller motor	Res.	Servoventil for turtall Trommel med hastighetsregulering
Øke	Minke						

FILE NAV 835ESA12

UTGAVE	ENDRING	DATO	SIGN.	GODKJ.	OPPR. TEGN.	ERST. FOR

ØVERAASEN A.S.

ASI
A.S. INDUSTRIAUTOMATIKK
P. Box 7044, N-2007 Drammen
Tel. 03 92 41 00 Fax 03 92 06 24

Snafreser TV 110-150-E25 S

2835	BL 12
	AV

